

HP 75000 SERIES B and C

Eight-Channel Fixed Filter and Amplifier Signal Conditioning Plug-on HP E1508

User's Manual

The HP E1503 manual also applies to HP E1413Bs as HP E1413 Option 18.

Enclosed is the User's Manual for the HP E1508 Signal Conditioning Plug-on. Insert this manual in your HP E1413/E1313 manual behind the "Signal Conditioning Plug-ons" divider.



Copyright © Hewlett-Packard Company, 1993, 1994, 1996



E1508-90001

HP E1508

Eight-Channel Fixed Filter and Amplifier Signal Conditioning Plug-on

Introduction

The HP E1508 is a Signal Conditioning Plug-on that provides eight fixed low-pass filters with a 3dB cutoff frequency of 7Hz and eight amplifiers with gain of 16. Also provided is input over-voltage protection and open transducer detection on each channel.

About this Manual

This manual shows you how to control the Signal Conditioning Plug-on (SCP) using SCPI commands as well as Register-Based commands, and explains the capabilities of this SCP. Finally, it covers specifications for this SCP. The contents of this manual are:

- Installation 1
- Identifying the Plug-on 1
- Connecting To The Terminal Module 2
- Programming With SCPI Commands 4
- Programming With Register Commands 6
- Specifications 8

Installation

Installation for this Plug-on is common to several others and is covered in Chapters 1 and 2 of your HP E1413/E1313 manual.

Identifying the Plug-on

You'll find the HP part number on the connector side of the SCP to the left of the serial number bar code. For the HP E1508, the part number is :
E1413-63518

Programming With SCPI Commands

The SCPI commands shown here are covered in Chapters 3 and 5 of your HP E1413/E1313 manual. This section will relate those commands to the parameter values which are specific to this Plug-on.

Checking the ID of the SCP

To verify the SCP type(s) installed on the HP E1413/E1313 use the SYSTem:CTYPe? (@<channel>) command.

- The *channel* parameter specifies a single channel in the channel range covered by the SCP of interest. The first channel number for each of the eight SCP positions are; 0,8,16,24,32,40,48, and 56.

The value returned for the SCP in an HP E1413B is:
HEWLETT-PACKARD,E1413 Opt 18 8-Channel Fixed Gain-Filter SCP,0,0

The value returned for the SCP in an HP E1313A/E1413C is:
HEWLETT-PACKARD,E1508 8-Channel Fixed Gain-Filter SCP,0,0

To determine the type of SCP installed on channels 0 through 7 send

SYST:CTYP? (@100) *query SCP type @ ch 0*
enter statement here

Querying the Filter Cutoff Frequency

While the HP E1508 does not provide programmable cutoff frequency the filter frequency can be queried. The response to this query will always be 7. To query any channel for its cutoff frequency use the INPut:FILTer[:LPASs]:FREQuency? (@<channel>) command. The INP:FILT:FREQ? command returns the numeric cutoff value currently set for the channel specified.

- The *channel* parameter must specify a single channel.

To query the cutoff frequency of channel 6 send

INP:FILT:FREQ? (@106) *query channel 6*
enter statement here

Querying the Filter State

While the HP E1508 does not allow controlling whether the filters are enabled or disabled, this state can be queried. The response to this query will always be 1. To query any channel to determine if it is enabled or disabled use the INPut:FILTer[:LPASs][:STATe]? (@<channel>) command. The INP:FILT? command returns a 0 if the channel is OFF or a 1 if the channel is ON.

- The *channel* parameter must specify a single channel.

To query the filter state of channel 2 send

```
INP:FILT? (@102)           query channel 2
enter statement here
```

Querying the Channel Gain

While the HP E1508's amplifiers have fixed gain, the channel gain can be queried. The response to this query will always be 16. To query any channel to determine its gain setting use the INPut:GAIN? (@<channel>) command. The INP:GAIN? command returns the current gain value for the specified channel.

- The channel parameter must specify a single channel.

To query the gain setting of channel 8 send

```
INP:GAIN? (@108)          query channel 8
enter statement here
```

Detecting Open Transducers

This SCP provides a method to detect open transducers. When Open Transducer Detect (OTD) is enabled, the SCP injects a small current into the HIGH and LOW input of each channel. The polarity of the current pulls the HIGH inputs toward +17 volts and the LOW inputs towards -17 volts. If a transducer is open, measuring that channel will return an over-voltage condition. OTD is available on a per SCP basic. all eight channels of an SCP are enabled or disabled together. See Figure 5 for a simplified schematic diagram of the OTD circuit.

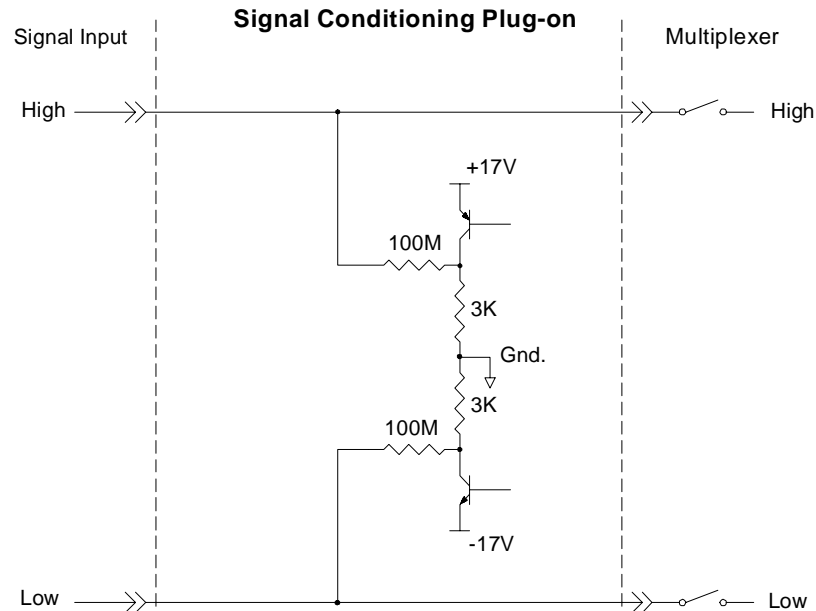

Figure 5 Open Transducer Detect Circuit

NOTES

1) When OTD is enabled, the inputs have up to 0.2µA injected into them. If this current will adversely affect your measurement, but you still want to check for open transducers, you can enable OTD, make a single scan, check the CVT for bad measurements, then disable OTD and make your regular measurement scans. The specifications apply only when OTD is off.

2) Allow 5 minutes before checking for open transducers to allow filter capacitors to charge.

To enable or disable Open Transducer Detection, use the DIAGnostic:OTDetect *<enable>*, (@*<ch_list>*) command.

- The *enable* parameter can specify ON or OFF
- An SCP is addressed when the *ch_list* parameter specifies a channel number contained on the SCP. The first channel on each SCP is: 0, 8, 16, 24, 32, 40, 48, and 56

To enable Open Transducer Detection on all channels on SCPs 1 and 3:

DIAG:OTD ON, (@100,116) *0 is on SCP 1 and 16 is on SCP3*

To disable Open Transducer Detection on all channels on SCPs 1 and 3:

DIAG:OTD OFF, (@100,116)

Register Based Programming

The register-based commands shown here are covered in Appendix D of the HP E1413/E1313 manual. You should read that section first to become familiar with accessing registers and executing Register-Based Commands. This section will relate those commands to the parameter values which are specific to this Plug-on.

When Register Programming an SCP most communication is through the Signal Conditioning Bus. For that you will use the Register Commands:

SCBWRITE *<regaddr>* *<regvalue>*

and

SCBREAD? *<regaddr>*

HP E1508 Register Map

Read (returned value)	Write(<regvalue>)	SCP Register	<regaddr> Value
SCP ID (9010 ₁₆)		Whole SCP Reg 0	00ppp000000 ₂

ppp=Plug-on
ccc=SCP channel

In addition you will access bits in the Card Control register to control Open Transducer Detection.

Checking ID of SCP

To query an SCP for its ID value, write the following value to Parameter Register 1:

$$(SCP\ number) \times 40_{16}$$

Then write the opcode for SCBREAD? (0800₁₆) to the Command Register. The ID value will be returned to the Query Response Register.

Detecting Open Transducers

Open Transducer Detection (OTD) is controlled by bits in the Card Control Register. For more information on OTD see Figure 1.

Card Control Register (Base + 12₁₆)

15	14	14-13	12	11	10-8	7-0
PSI Pwr Reset	FIFO Mode	unused	FIFO Clear	VPPEN	A24 Window	Open Transducer Detect

Writing a one (1) to a bit enables open transducer detect on that signal conditioning module. Writing a zero (0) to a bit disables open transducer detect.

Bit 7	Bit 6	Bit 5	Bit 4	Bit 3	Bit 2	Bit 1	Bit 0
SCP 7	SCP 6	SCP 5	SCP 4	SCP 3	SCP 2	SCP 1	SCP 0

Specifications

These specifications for the HP E1508 reflect the combined performance of the HP E1413/E1313 and the HP E1508 Signal Conditioning Plug-on. These specifications are not to be added to those presented in the HP E1413/E1313 User's Manual.

General Specifications

Measurement ranges

DC Volts	$\pm 3.9\text{mV}$ to $\pm 1\text{V}$ FS
Temperature	Thermocouples - -200 to $+1700$ °C Thermistors - (Opt 15 required) -80 to $+160$ °C RTD's - (Opt 15 required) -200 to $+850$ °C
Resistance	(Opt 15 required) 128 ohms to 131 Kohms FS
Strain	25,000 $\mu\epsilon$ or limit of linear range of strain gage

Maximum input voltage Operating: $< \pm 16$ V peak Damage level: $> \pm 42$ V peak
(Normal mode plus common mode)

Maximum common mode voltage Operating: $< \pm 16$ V peak Damage level: $> \pm 42$ V peak

Normal mode rejection @ 7Hz -3dB, @ 60Hz $> -25\text{dB}$

Common mode rejection 0-60Hz -100dB

Input impedance 100 Mohm $\pm 10\%$ (each differential input to ground)

Maximum tare cal offset (Maximum tare offset depends on A/D range and SCP gain)

A/D range $\pm\text{V F.Scale}$	16	4	1	0.25	0.0625
Max Offset	.20009	.05007	.01317	.00349	.00112

**Measurement accuracy
DC Volts**

(90 days) 23°C ±1°C (with *CAL? done after 1 hr warm up and CAL:ZERO? within 5 min.). If autoranging is ON, add ±.02% FS to accuracy specifications.
For E1313, multiply Noise Spec. by 1.4.

Gain 16	Range ±V FS	Linearity % of reading	Offset Error µV (10Hz)	Noise µV 3 sigma	Noise µV* 3 sigma
	.0039	0.01	3.8	3.4	2.9
.0156	0.01	4.2	4.4	3.8	
.0625	0.01	4.9	7.5	6.3	
.25	0.01	8	28	23	
1	0.01	31	113	64	

* [SENSe:]FILTeR[:LPASs][:STATe] ON (max scan rate - 100 rdgs/sec/channel)

Temperature Coefficients: Gain - 15ppm/°C. Offset - (0 - 30°C) .16µV/°C, (30 - 40°C) .18µV/°C,
(40 - 55°C) .39µV

**BMeasurement accuracy
Temperature**

(90 days) 23°C ±1°C (with *CAL? done after 1 hr warm up and CAL:ZERO? within 5 min.). If autoranging is ON, add ±.02% FS to accuracy specifications.

(simplified specifications, see temperature accuracy graphs in HP E1413/E1313 manual for details)

The temperature accuracy specifications include instrument and firmware linearization errors. The linearization algorithm used is based on the IPTS-68(78) standard transducer curves. Add your transducer accuracy to determine total measurement error.

Thermocouples

Type E	A/D Filter	-200 to 0 °C	0 to 200 °C	200 to 400 °C	400 to 800 °C
	OFF	1.30°C	0.14°C	0.14°C	0.20°C
Type EExtended	A/D Filter	-200 to 0 °C	0 to 200 °C	200 to 800 °C	800 to 1000 °C
	OFF	1.80°C	0.30°C	0.20°C	0.35°C
Type J	A/D Filter	-200 to 0 °C	0 to 280 °C	280 to 600 °C	600 to 775 °C
	OFF	1.60°C	0.15°C	0.22°C	0.22°C
Type K	A/D Filter	-200 to 0 °C	0 to 375 °C	375 to 800 °C	800 to 1400°C
	OFF	2.50°C	0.20°C	0.25°C	0.40°C
Type R	A/D Filter	0 to 100 °C	100 to 200 °C	200 to 600 °C	600 to 1000 °C
	OFF	1.80°C	0.90°C	0.70°C	0.60°C

[SENSe:]FILTeR[:LPASs][:STATe] ON (max scan rate - 100 rdgs/sec/channel)

**Measurement accuracy
Temperature (cont.)**

(simplified specifications, see temperature accuracy graphs in HP E1413/E1313 manual for details)

Thermocouples (cont.)

Type S	A/D Filter	0 to 100 °C	100 to 200 °C	200 to 800 °C	800 to 1750 °C
	OFF	3.50°C	1.75°C	0.80°C	0.85°C
Type T	A/D Filter	-200 to -100°C	-100 to 0 °C	0 to 200 °C	200 to 400 °C
	OFF	1.55°C	0.32°C	0.18°C	0.18°C

5KΩ Reference Thermistor

A/D Filter	-10 to 65 °C	65 to 85 °C
OFF	0.012°C	0.013°C

100Ω Reference RTD

A/D Filter	-125 to 70°C
OFF	0.145°C

100Ω RTD

A/D Filter	-200 to 75 °C	75 to 300 °C	300 to 600 °C	600 to 970 °C
OFF	0.08°C	0.21°C	0.27°C	0.37°C

2252Ω Thermistor

A/D Filter	0 to 30 °C	30 to 70 °C	70 to 80 °C	80 to 100 °C
OFF	0.006°C	0.013°C	0.010°C	0.014°C

5KΩ Thermistor

A/D Filter	0 to 30 °C	30 to 70 °C	70 to 85 °C
OFF	0.012°C	0.014°C	0.019°C

10KΩ Thermistor

A/D Filter	0 to 30 °C	30 to 60 °C	60 to 90 °C	90 to 115 °C
OFF	0.015°C	0.016°C	0.018°C	0.022°C